

ISOMETER® 107TD47

Insulation monitoring device with load current and temperature monitoring for IT systems in medical locations in accordance with DIN VDE 0100-710 and IEC 60364-7-710

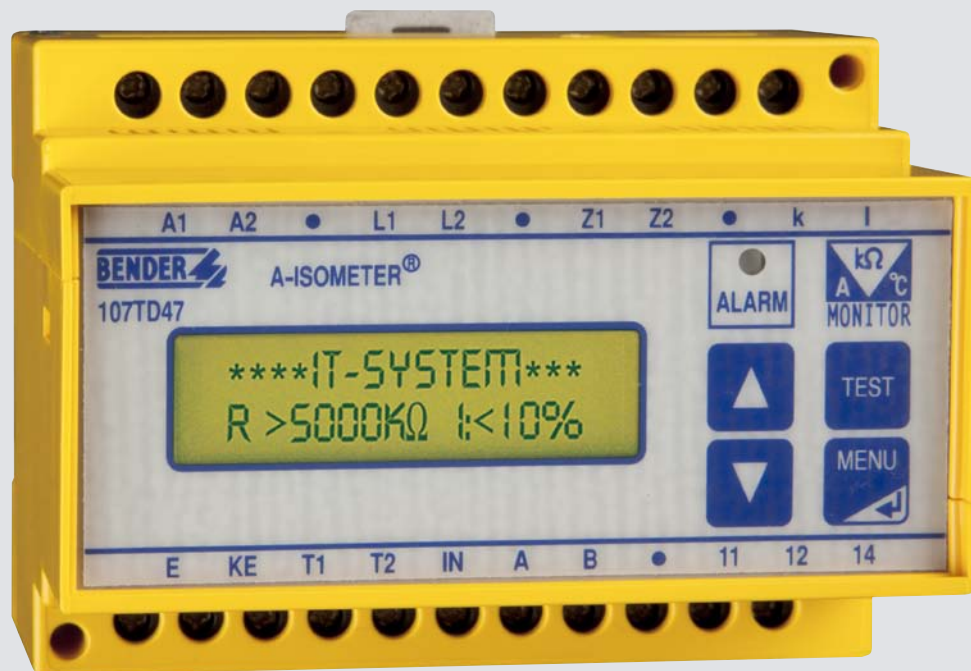

ISOMETER® 107TD47

Insulation monitoring device with load current and temperature monitoring for IT systems in medical locations in accordance with DIN VDE 0100-710 and IEC 60364-7-710



ISOMETER® 107TD47

Device characteristics

- Monitoring device for medical IT systems AC, 3(N)AC
- Adjustable response value 50...500 kΩ
- Load and temperature monitoring
- Alarm LED
- Monitoring of the connection to the system, earth, measuring current transformer, temperature sensors
- Test button
- External test button can be connected
- BMS-bus interface
- Common alarm relay with one potential-free changeover contact
- Backlit LC display

Approvals



Product description

The ISOMETERs® of the 107TD47 series monitor the insulation resistance of single and three-phase AC IT systems in medical locations. In addition, the IT system transformer is monitored for overload and overtemperature. In combination with the alarm indicator and test combination MK2418 they particularly comply with the requirements of DIN VDE 0100-710 (VDE 0100 Teil 710) and IEC 60364-7-710.

Application

- IT systems for the power supply in medical locations, hospitals, medical practices and outpatient surgical centres
- IT systems with restricted power source with additional load current monitoring

Function

If one of the measured values exceeds the limiting value (insulation resistance, load current, temperature), an alarm is initiated. The alarm relay switches, the ALARM LED lights up and a message appears on the LC display. This alarm message is transferred to remote MK2418 alarm indicator and test combinations installed in the medical location via two-wire interface so that the technical or medical staff is informed immediately.

The measuring leads to the system and PE, to the current transformer and to the temperature sensor are monitored continuously. If one of these measuring leads is interrupted or short-circuited, a message will appear. The function of the device can be checked by pressing the Test button.

The insulation resistance of operating theatre lamps often is monitored by another insulation monitoring device that activates a relay contact in case of alarm (voltage-free NO contact). The alarm message of this contact is recorded by the 107TD47 and transferred via the BMS (Bender Measuring Device Interface) bus to other BENDER devices such as a remote alarm indicator and test combination.

In order to detect the load current in three-phase systems, an LSD470 measuring adaptor is required which in combination with the STW2 current transformers measures the current of the phase conductors. The highest value of the load current is evaluated by the electronics and is made available at the input k/I of the 107TD47.

Measuring principle



The ISOMETER® 107TD47 uses the AMP measuring principle. That ensures safe monitoring of modern power supply systems, even in case of insulation faults including DC components (e. g. patient monitoring).

Standards

The 107TD47 series ISOMETER® complies with the requirements of the device standards: DIN EN 61557-8 (VDE 0413-8), EN 61557-8, IEC 61557-8, DIN VDE 0100-710 (VDE 0100-710), IEC 60364-7-710, ASTM F 1207 1996-00

Wiring diagram/operating elements

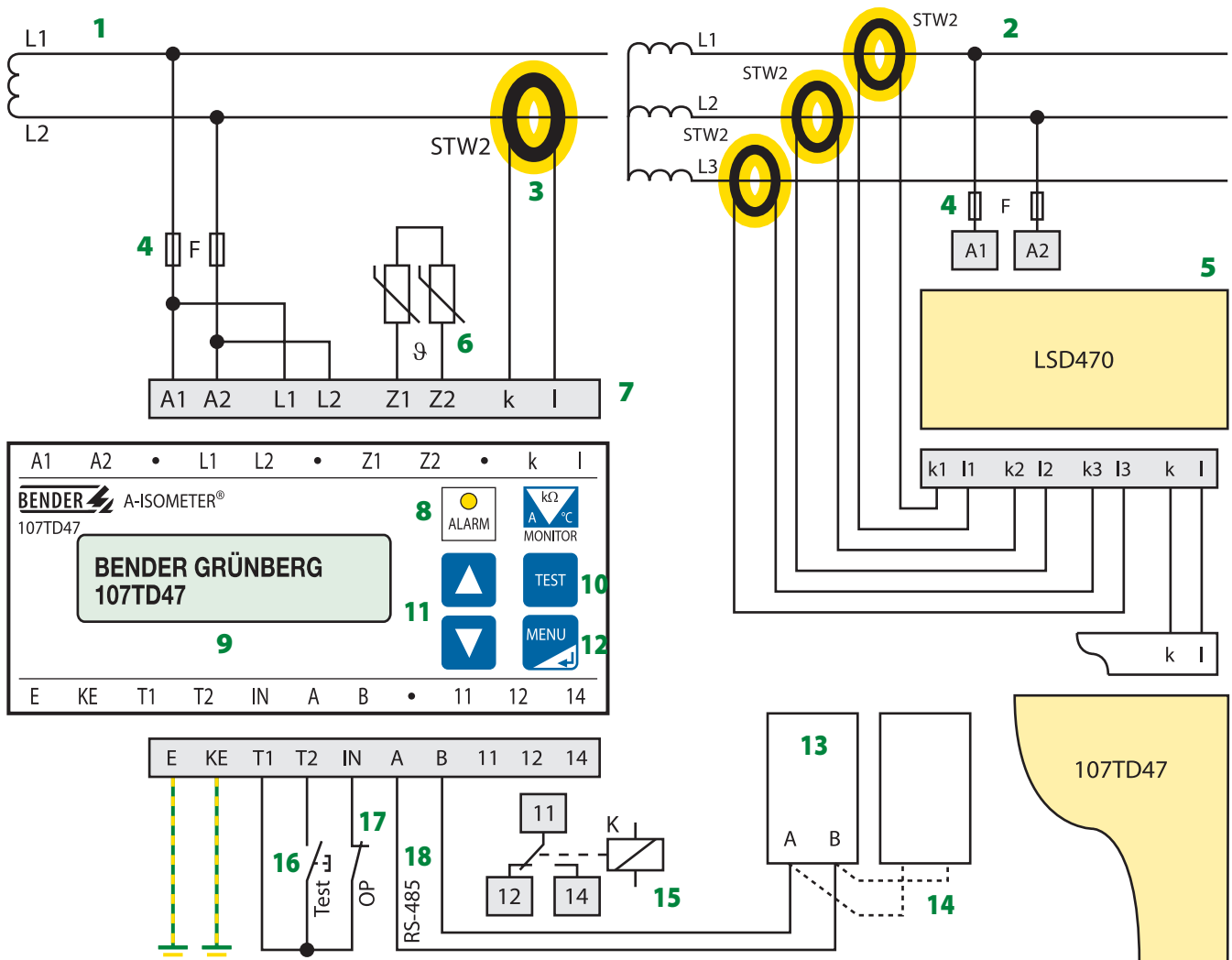

- 1 - AC IT system
- 2 - 3AC IT system
- 3 - STW2 Measuring current transformer for load current monitoring
- 4 - Short-circuit protection supply voltage, 6 A fuse recommended
- 5 - LSD470 Three-phase adapter for load current monitoring 3AC systems
- 6 - PTC resistors (or N/C contacts) in the transformer winding. Will operate when the temperature in the transformer core reaches an excessive level. Max. 6 PTC thermistors should be connected in series, cable length max. 3 m
- 7 - The measuring connections L1, L2, k, I, Z1, Z2, E, KE are monitored for interruption resp. short-circuit (k, I). A1 and A2 are intended for the power supply of the 107TD47 resp. LSD470
- 8 - Alarm LED "ALARM"
- 9 - Display
- 10 - "TEST" button in display mode: activates the test function (self test). In the menu mode: causes a return to the display mode from any position. If activated during a parameter change, the last change will not be stored.
- 11 - In the menu mode: for navigation within the menus and for setting parameters. Adjustment: upwards/in ascending resp. downwards in descending order. No function in the display mode.
- 12 - "MENU" button: Changes from the display mode to the menu mode. In the menu mode: this button serves as an Enter button.
- 13 - Alarm indicator and test combination MK2418-12
- 14 - TM operator panels
- 15 - Alarm relay without fault memory to signal insulation faults, overcurrent, overtemperature and device errors.
- 16 - Optional external test button for testing the insulation monitoring function (42 kΩ test resistance) and the measuring circuits for load current and temperature.
- 17 - Input "IN" for displaying the message "Insulation fault operating theatre light", initiated by the N/C contact of the respective insulation monitoring device
- 18 - BMS-bus interface "RS-485", e.g. for the connection of alarm indicator and test combinations or panels.

Interconnection diagram

AC system

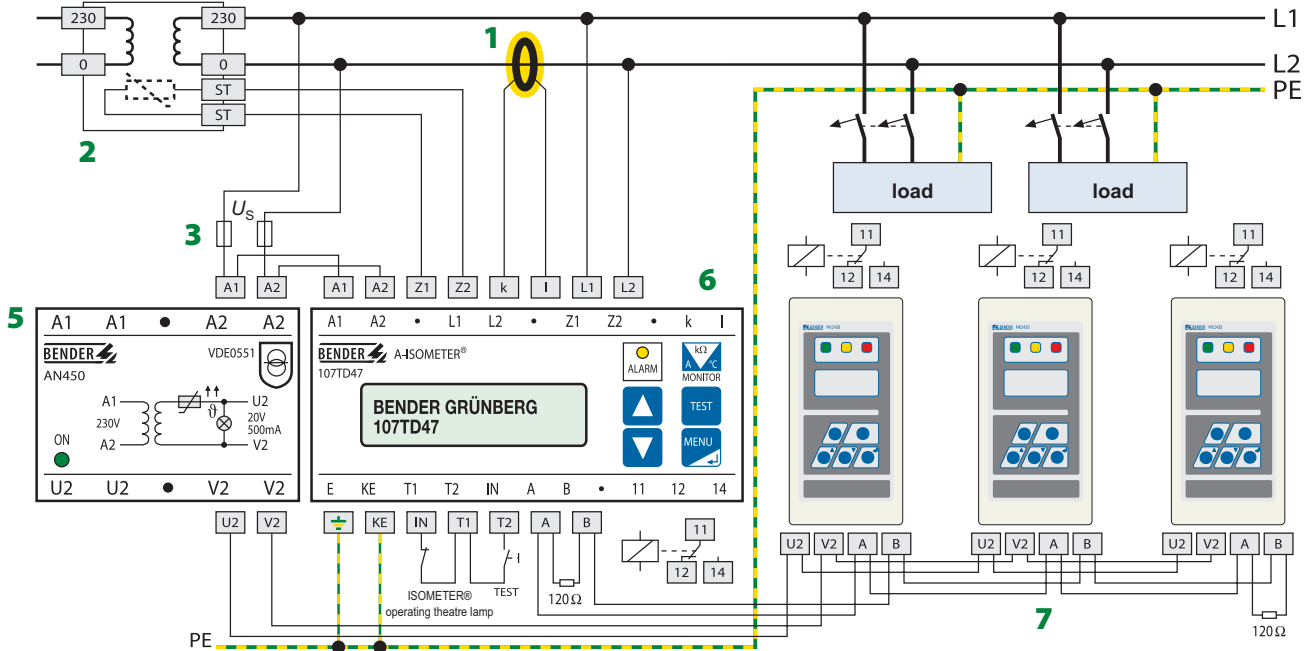

3(N)AC system

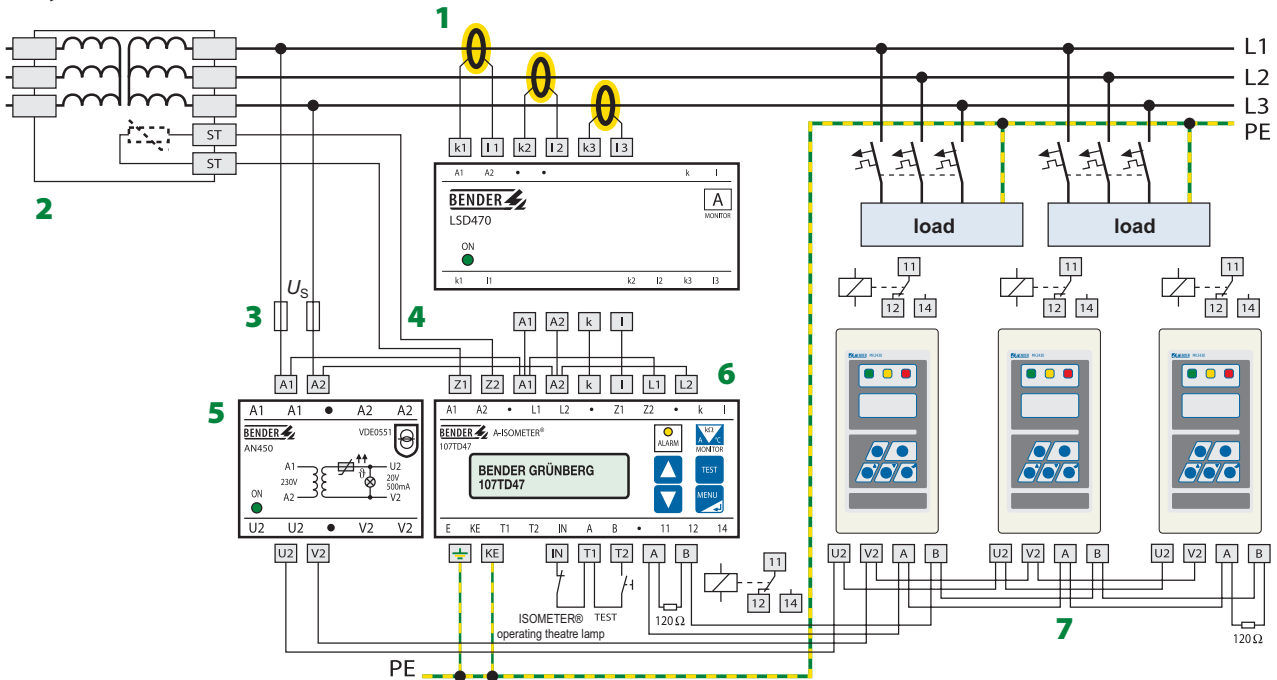

- 1 - Measuring current transformers for load current monitoring
- 2 - Temperature sensor, isolating transformer ES0107
- 3 - 6 A fuse (recommended)
- 4 - LSD470 measuring adapter

- 5 - Power supply unit AN450 for max. 3 MK2430
- 6 - ISOMETER® 107TD47
- 7 - Alarm indicator and test combination MK2430

Technical data

Insulation coordination acc. to IEC 60664-1

| | |
|--|----------|
| Rated insulation voltage | AC 250 V |
| Rated impulse withstand voltage/pollution degree | 4 kV/3 |

Voltage ranges

| | |
|---|--------------------------|
| Nominal system voltage U_n /Nominal frequency f_n | see ordering information |
| Supply voltage U_S | see ordering information |
| Operating range of U_S | 0.85...1.15 x U_S |
| Frequency range U_S | 40...460 Hz |
| Power consumption | ≤ 3 VA |

Measuring circuit insulation monitoring

| | |
|---|-------------|
| Response value R_{an} | 50...500 kΩ |
| Relative uncertainty | 0...+10 % |
| Response time t_{an} at $R_F = 0.5 \times R_{an}$ and $C_e = 1 \mu F$ | 3 s |
| Hysteresis | 25 % |
| Measuring voltage U_m | ≤ 12 V |
| Measuring current I_m max. (at $R_F = 0 \Omega$) | ≤ 50 μA |
| Internal DC resistance R_i | ≥ 240 kΩ |
| Impedance Z_i at 50 Hz | ≥ 200 kΩ |
| Permissible extraneous DC voltage U_{fg} | ≤ DC 375 V |
| Permissible system leakage capacitance | ≤ 5 μF |

Measuring circuit load current monitoring

| | |
|-----------------------|-------------|
| Response value | 5...50 A |
| Hysteresis | 4 % |
| Temperature influence | < 0.15 %/°C |

Measuring circuit temperature monitoring

| | |
|---------------------------------|------------------|
| Response value | 4 kΩ |
| Release value | 1.6 kΩ |
| PTC resistors acc. to DIN 44081 | max. 6 in series |

Displays

| | |
|--|----------------------------|
| Display (illuminated)/characters(number, height) | LC display/2 x 16 (3.5 mm) |
| Display range, measured value | 10...5000 kΩ |
| Operating uncertainty in accordance with IEC 61557-8 | ± 10 % |

Inputs

| | |
|--|-------------|
| Test button | N/O contact |
| Message "Insulation fault operating theatre light" | N/C contact |
| Cable length inputs max. | 10 m |

Outputs

| | |
|-------------|-------------------|
| Test button | internal/external |
|-------------|-------------------|

Interfaces

| | |
|---|------------------------------------|
| Interface/protocol | RS-485/BMS |
| Max. cable length 1200 m | |
| Cable (twisted in pairs, one end of shield connected to PE) | recommended: J-Y(St)Y min. 2 x 0.8 |
| Terminating resistor | 120 Ω (0.25 W) |

Switching elements

| | |
|--|--|
| Number of switching elements | 1 changeover contact |
| Operating principle | N/O operation/N/C operation |
| Factory setting | N/O operation |
| Electrical endurance, number of cycles | 12000 |
| Contact class | IIB |
| Rated contact voltage | AC 250 V/DC 300 V |
| Making capacity | AC/DC 5 A |
| Breaking capacity | 2 A, AC 230 V, cos phi = 0.4 - 0.2 A, DC 220 V, L/R = 0.04 s |
| Minimum contact current at DC 24 V | 2 mA (50 mW) |

Environment

| | |
|---|---------------------------|
| Shock resistance IEC 60068-2-27 (during operation) | 15 g/11 ms |
| Bumping IEC 60068-2-29 (transport) | 40 g/6 ms |
| Vibration resistance IEC 60068-2-6 (during operation) | 1 g/10...150 Hz |
| Vibration resistance IEC 60068-2-6 (transport) | 2 g/10...150 Hz |
| Ambient temperature (during operation/during storage) | -10...+55 °C/-40...+70 °C |
| Climatic class acc. to DIN IEC 60721-3-3 | 3K5 |

Connection

| | |
|--------------------------------------|--|
| Connection type | modular terminals |
| Connection properties rigid/flexible | 0.2...4 mm ² /0.2...2.5 mm ² |

Other

| | |
|--|----------------------|
| Operating mode | continuous operation |
| Mounting | any position |
| Degree of protection, internal components (DIN EN 60529) | IP30 |
| Degree of protection, terminals (DIN EN 60529) | IP30 |
| Screw mounting | 2 x M4 |
| DIN rail mounting acc. to | IEC 60715 |
| Flammability class | UL94 V-0 |
| Operating manual | TBP201002 |
| Weight | ≤ 400 g |

Ordering information

| Nominal system voltage U_n (V) | Supply voltage U_S (V) | Type | Art. No. |
|----------------------------------|--------------------------|-------------|-------------|
| AC | AC | | |
| 230 V, 50...60 Hz | 230 V, 50...60 Hz | 107TD47 | B 9201 6003 |
| 127 V, 50...60 Hz | 127 V, 50...60 Hz | 107TD47-133 | B 9201 6004 |

Suitable system components

| Type designation | Supply voltage U_S (V) | Type | Art. No. |
|--------------------------------|--------------------------|-----------|-----------|
| | AC | | |
| Measuring current transformers | — | STW2 | B 942 709 |
| Power supply unit | 230 V | AN450 | B 924 201 |
| | 127 V | AN450-133 | B 924 203 |
| Measuring adapter | 230 V | LSD470 | B 986 782 |

Dimension diagram X470

Dimensions in mm

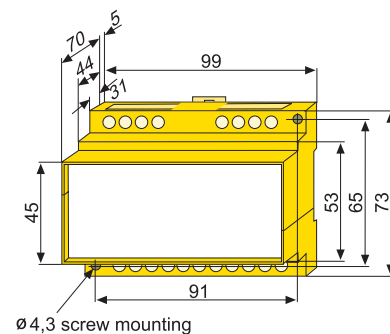



Bender GmbH & Co. KG

P.O. Box 1161 • 35301 Grünberg • Germany
Londorfer Straße 65 • 35305 Grünberg • Germany
Tel.: +49 6401 807-0 • Fax: +49 6401 807-259
E-Mail: info@bender-de.com • www.bender-de.com

BENDER Group